

# TR-WE45-A-IN PTZ Dome Wall Mount



## Specifications

Bracket	TR-WE45-A-IN
Application	Indoor or outdoor, wall installation for PTZ dome camera
Dimensions(L x W x H)	216mmx141mmx314mm(8.5" x 5.6" x 12.4")
Weight	1.0kg(2.2lb)
Material	Aluminum alloy

## Dimensions

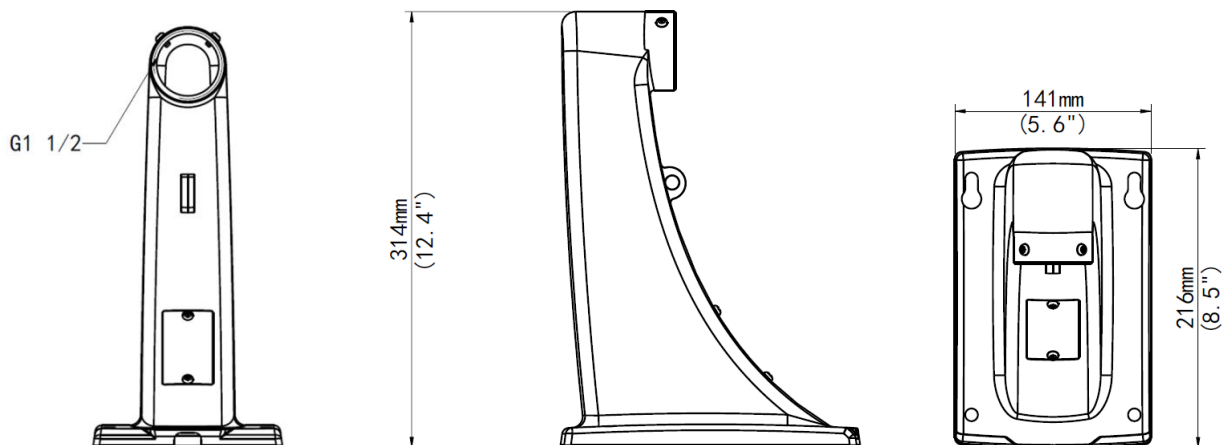

Zhejiang Uniview Technologies Co.,Ltd.

South Tower, Building 10, Wanlun Science Park, 88 Jiangling Road, Hangzhou, P.R.China 310051

Email: [overseasbusiness@uniview.com](mailto:overseasbusiness@uniview.com); [globalsupport@uniview.com](mailto:globalsupport@uniview.com)

<http://www.uniview.com>

©2015 Zhejiang Uniview Technologies Co.,Ltd. All rights reserved.

\*Product specifications and availability are subject to change without notice.