



For industrial usaga

# GULLIVER/N



Inverter  
technology

**NEW**

Q3 2023



Automation for industrial sliding gates up to  
4000 Kg

Available with single-phase motor 230 V or  
three-phase motor 415 V



## DIMENSIONS

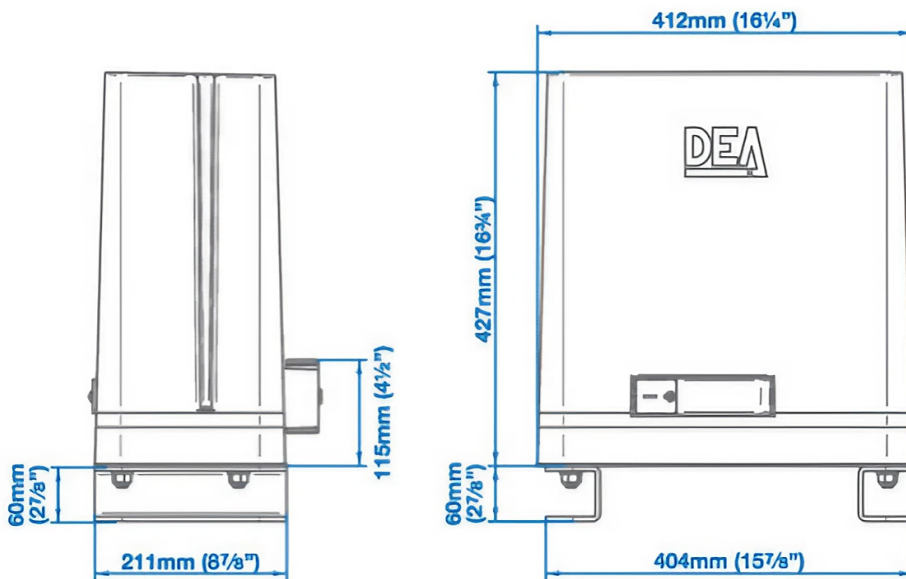

## TECHNICAL INFORMATION

Model	GULLIVER/N/M
Motor Power Supply (V)	230 V a.c.
Capacity (W)	860
Incorporated Condenser (uF)	30 uF
Duty Cycle (cycles/hour) For a 12m lef length	13
Max Thrust (N)	1300
Max Gate Weight (Kg)	2000 up to 3000
Motor Thermal Protection (°C)	140°C
Operating Temperature Range (°C)	-20° 50°
Operating Speed (m/min)	10.4
Standard Pinion	Z=18 (m=4mm)
Weight of Product with Package (Kg)	30
Sound Pressure Emitted (dBA)	< 70
Protection Degree	IP55 (IPX0 for/ IB versions)