

AC SLIDING GATE MOTOR

AC800

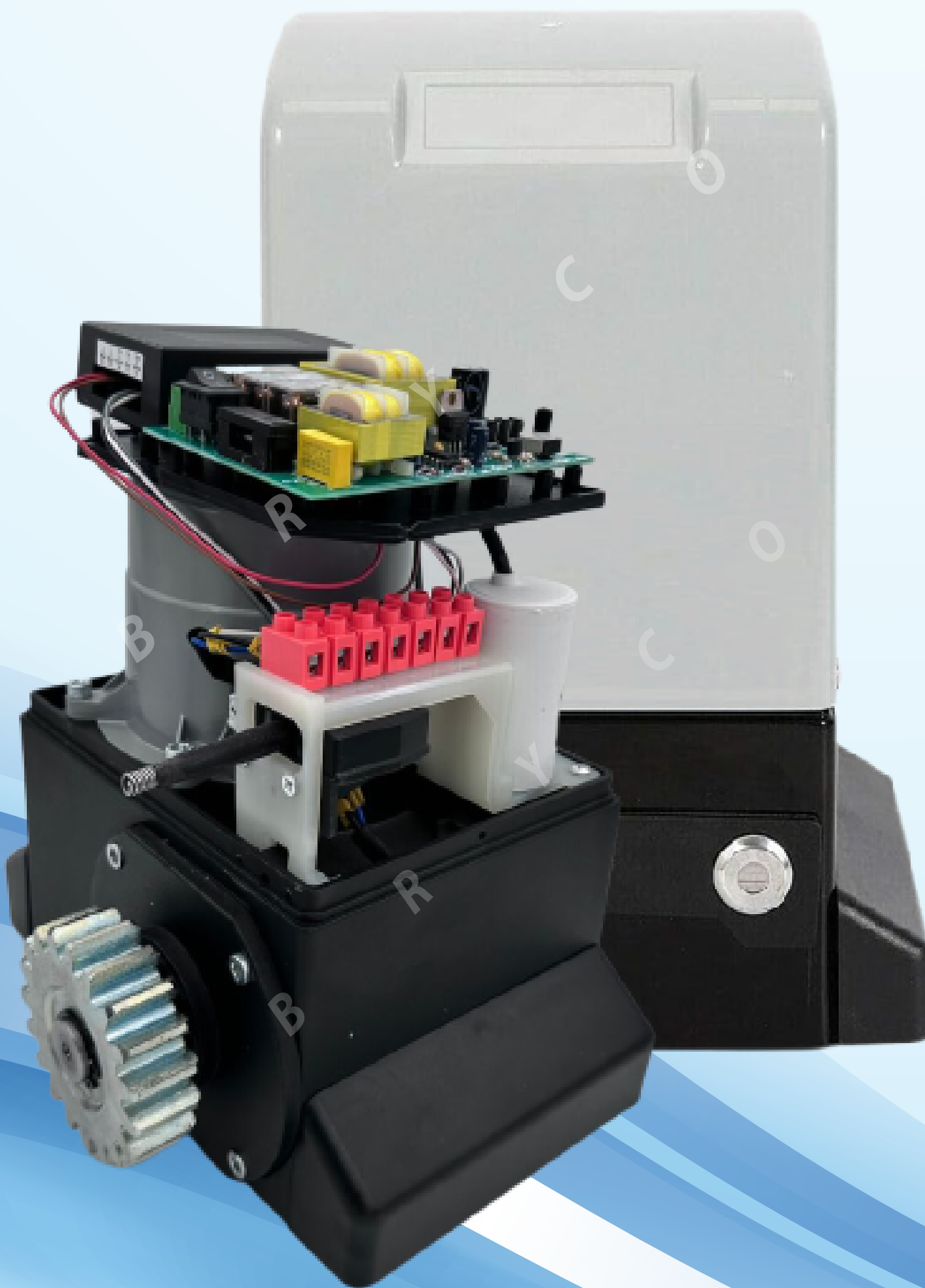

FEATURE



Suitable for gate from 400kg - 800kg

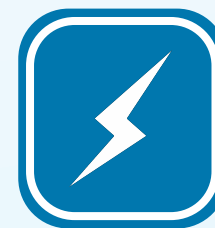

Electromechanical automation 240V



High quality electronic and mechanical components



Comfortable unlocking motor with release key when power failure



Soft start to ensure a smooth start and smooth operation of the motor.



Come with a weatherproof base cover to prevent screws from rusting



Fast and easy unlock device with release key



Fully built-in compact design

DIMENSION

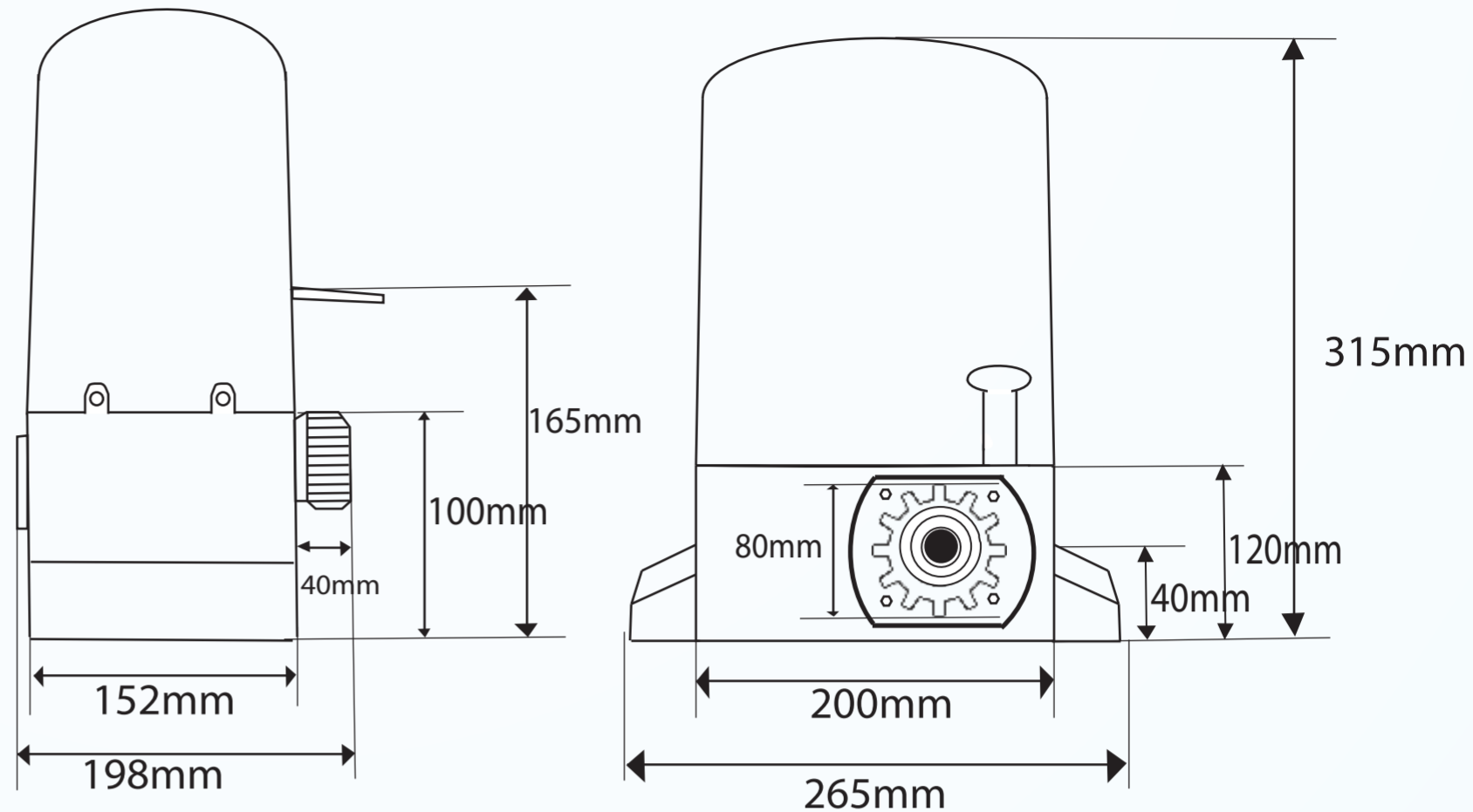

SPECIFICATIONS

Operating Voltage	AC 220-240V , 50Hz
Output Power	600W
Current	5A Max
Motor Rotation Speed	1400 RPM
Max. Weight of Gate	800 kg
Linear Speed	12m/min
Safety Cut Off / Auto Reverse	Electronic Load Surge Detector
Safety Limit Timer	Yes
Lubrication	Grease Type

ACCESSORIES

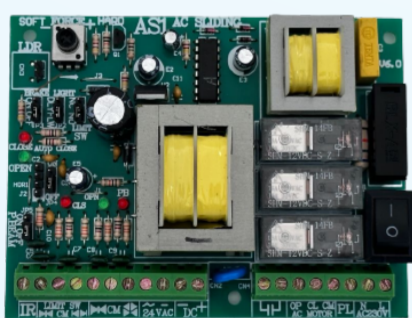

AS1
Sliding Type Control Panel



Remote Control set
1x Receiver , 3x Transmitter



Capacitor 16UF
(Sliding Gate Use)



Limit Switch c/w Spring



Emergency Release
Allen Key x 2pcs



Metal Gear



Spare Part set
Mounting Plate and screw ,
Limit Switch Stopper
(1 pair)



Gear Rack x1 pack
4 meter gear rack
with screw and nuts